

€

L I G H T  €

LED LAMPS | CREATE A COLOURFUL AMBIENCE

# LIGHTWAVE LED LAMPS | made in Switzerland

## CREATE A COLOURFUL AMBIENCE

With their ability to give out every colour in the spectrum, LightWave LED lamps create just the right atmosphere, whatever the setting – conference room, reception area, foyer or living room. The elegantly simple design, complemented by the quality of the materials used, gives the lamps a timeless, modern aesthetic.

A specific colour, or the automated colour-sequencing feature, can be conveniently selected by remote control. Integrated into the suspended lamp are dimmable, high-powered, white LEDs that give out a light that's ideal in a work setting.

With their pleasing lines, LightWave's LED lamps blend into any room and create just the right lighting mood for every working and living environment.

## CUSTOM PRODUCTS

We would be delighted to be given the opportunity of tailoring our designs to your individual requirements: we can engrave room numbers, emergency exit signs, etc. We can also program an arrangement of suspended lamps, or supply custom designs such as floor lamps without bases, or lamps in the form of display shelving, and lots more.

## CONTACT

LightWave LED Products | Schlattweg 558 | 5704 Egliswil | Switzerland  
tel +41 62 775 31 54 | fax +41 62 775 33 14  
info@lightwave-led.com | www.lightwave-led.com

# 12.1001

## 12.1001 - REMOTE CONTROL

Small, functional and elegantly simple. The stylish infrared remote control allows you to conveniently control every model of LightWave lamp individually. Such sophisticated control lies at the very heart of the LightWave lighting system.

- > On/Off button
- > Colour selection at the press of a button
- > Automation mode
- > Dimmer function
- > On/off button for the high-powered, white LEDs in the suspended lamp



# I2.600I



## I2.600I - SUSPENDED LAMP

LightWave's suspended lamp combines optimal functionality with a flair for interior design. As with all LightWave lamps, you can select specific colours or an automated lightshow that sequences through all the colours; additionally, the suspended lamp lets you switch in high-powered, white LEDs, providing functional as well as coloured mood lighting for conditions perfectly tailored to your requirements.

- > High-powered, white LEDs (dimnable)
- > Select between 26 different colours
- > Automated colour sequencing throughout the spectrum
- > Remote control
- > Energy-saving

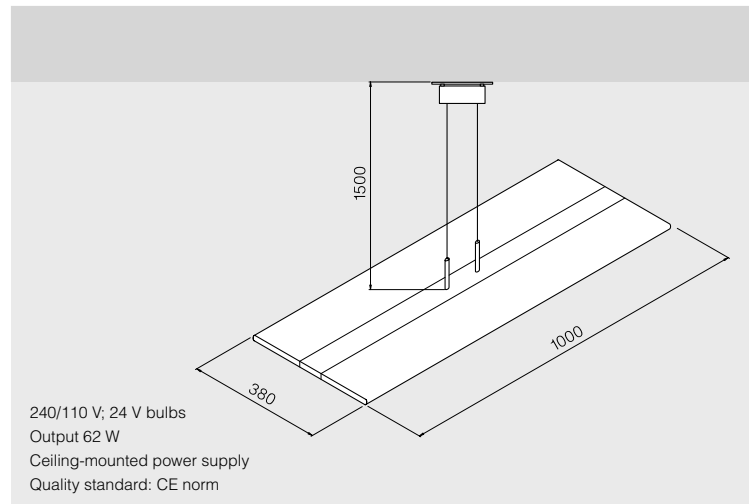

# I2.6002

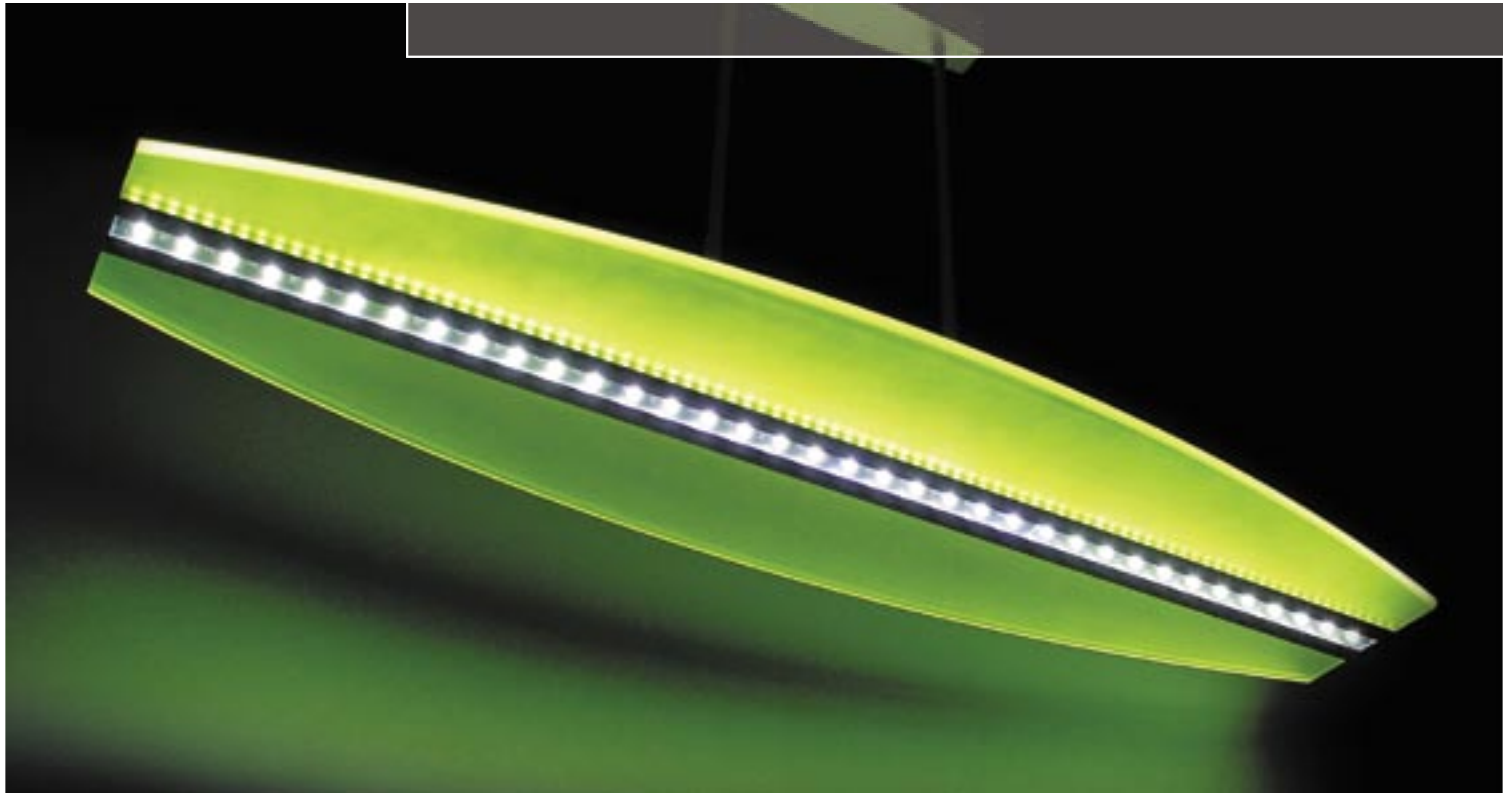

## I2.6002 - SURF

LightWave's suspended lamp gives the room an aesthetic accent and provides ideal light for any living or working space, as well as a colourful ambience. SURF optimally combines functionality with flair for interior design. In addition to sequencing through all the colours, high-powered white LEDs can be inserted at any time. The lamp shape features narrowing parallel curves on both sides, giving it a timeless, yet modern look.

- > High-powered, white LEDs (dimnable)
- > Select directly from 26 colours and white light
- > Automated colour sequencing (through the entire spectrum)
- > Remote control
- > Energy saving
- > Also available in rectangular design

## CONTACT

LightWave LED Products | Schlattweg 558 | 5704 Egliswil | Switzerland  
tel +41 62 775 44 35 | fax +41 62 775 33 14  
info@lightwave-led.com | www.lightwave-led.com

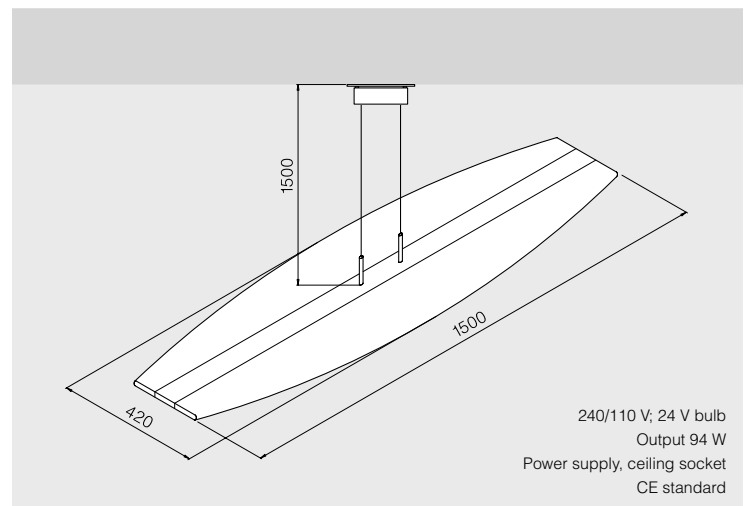

# I2.6003

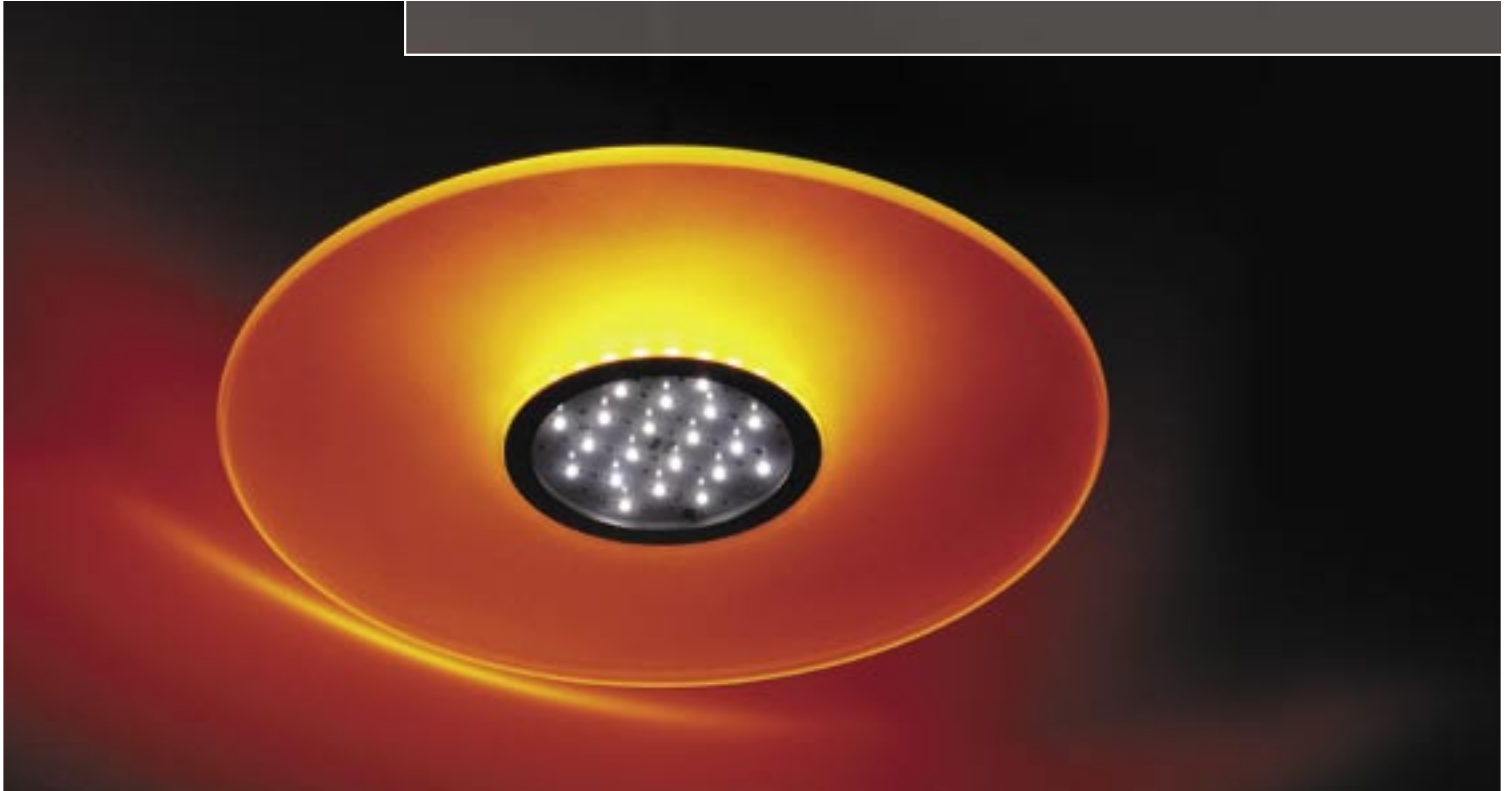

## I2.6003 - UFO

LightWave's UFO suspended lamp takes the circle as an ideal shape into its shape collection. The lamp is adjustable in height, making it suitable as a ceiling or suspended lamp. In addition to sequencing through all the colours, high-powered white LEDs can be inserted in at any time. UFO, with its neutral circular shape, blends perfectly into any setting.

- > High-powered, white LEDs (dimnable)
- > Select directly from 26 colours and white light
- > Automated colour sequencing (through the entire spectrum)
- > Remote control
- > Energy saving
- > Doubles as a ceiling lamp

### CONTACT

LightWave LED Products | Schlattweg 558 | 5704 Egliswil | Switzerland  
tel +41 62 775 44 35 | fax +41 62 775 33 14  
info@lightwave-led.com | www.lightwave-led.com

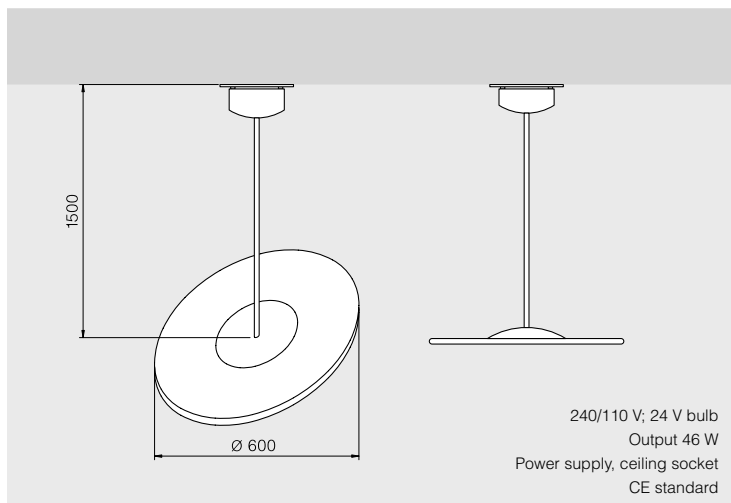

# I2.700I



## I2.700I - FLOOR LAMP

With its soaring, slim design, LightWave's floor lamp comes across as a standalone and discreetly modern objet d'art. It blends harmoniously into any setting, creating a pleasant ambience.

- > Select between 26 different colours
- > Automated colour sequencing throughout the spectrum
- > Remote control
- > Energy-saving

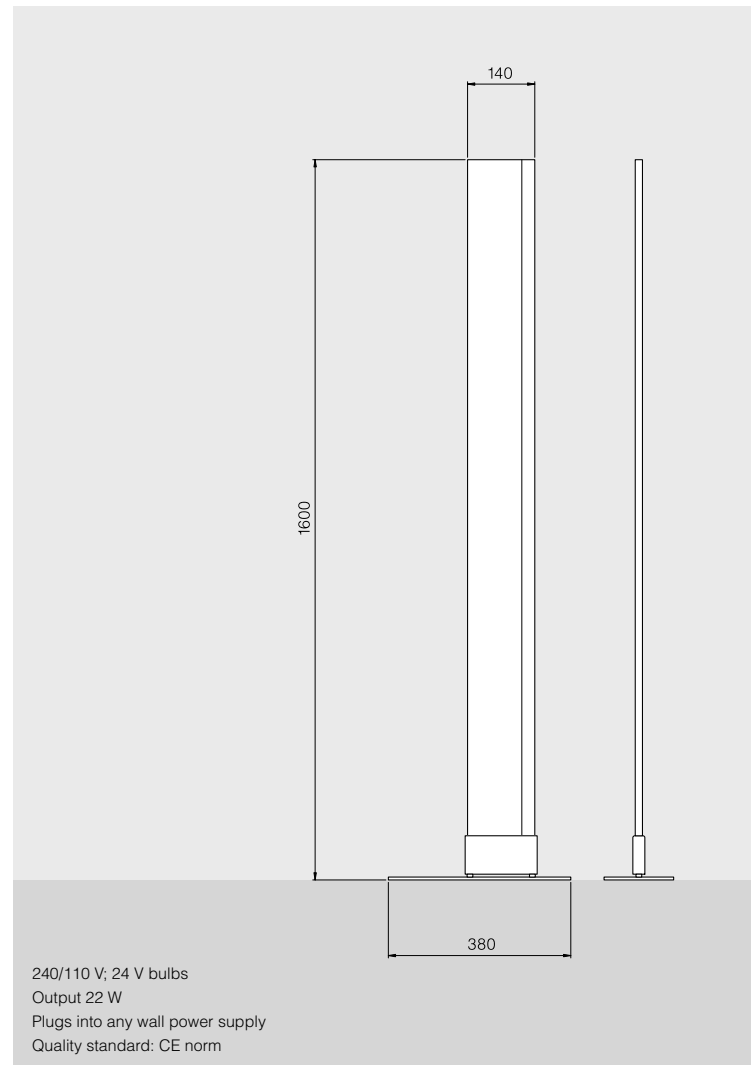

# I2.8000

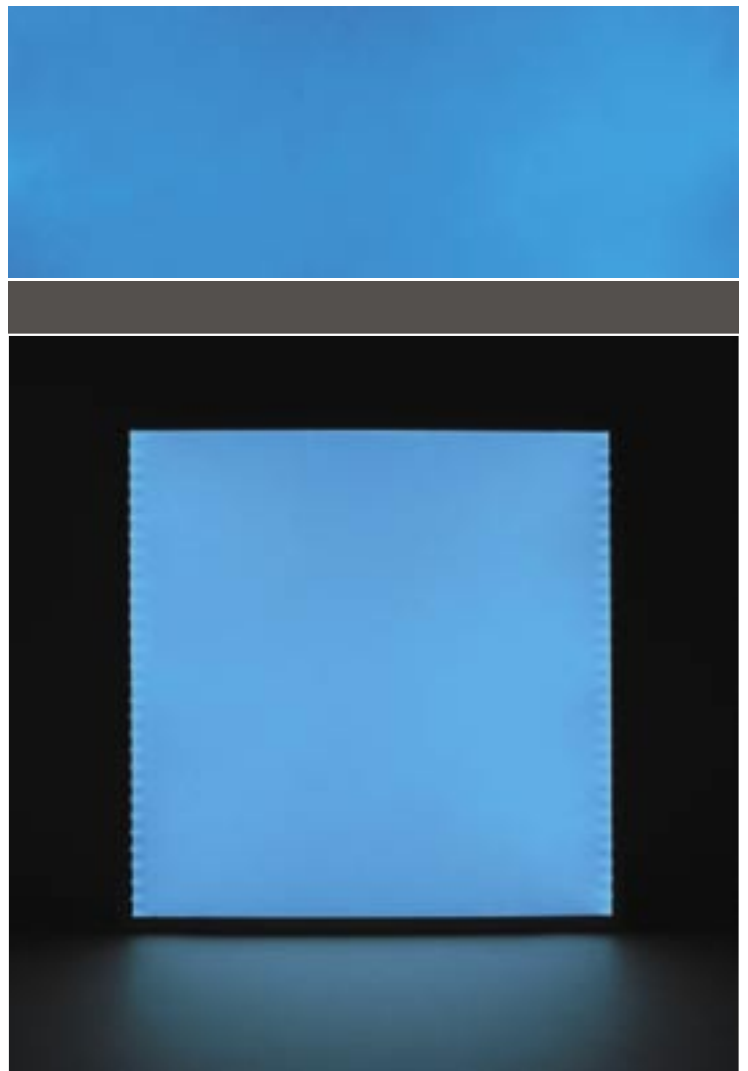
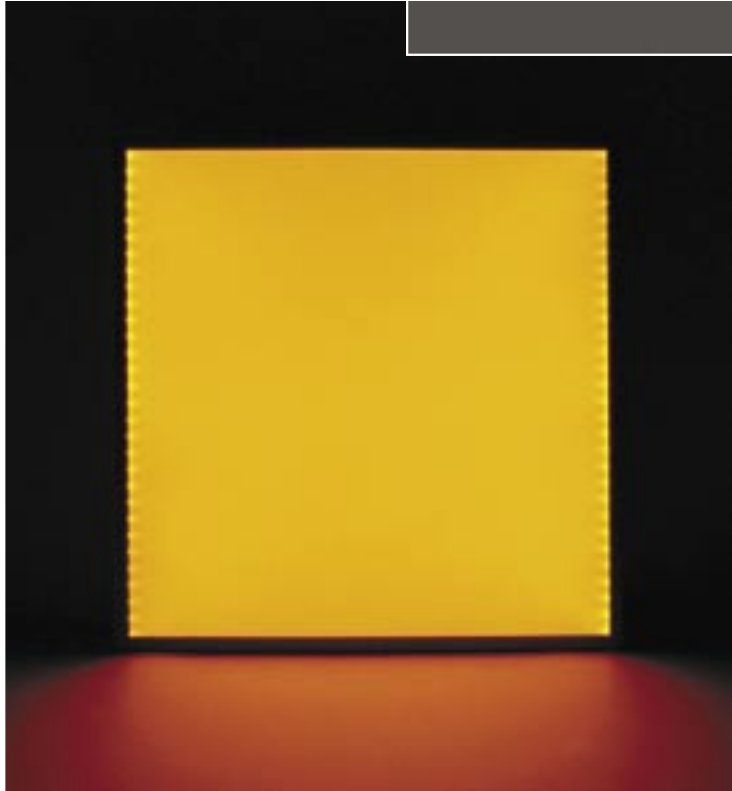

## I2.8000 - FLAT

The simplicity of the rectangle or the static perfection of a square - FLAT, LightWave's wall lamp expresses its own stylistic features. FLAT appeals with authentic clarity and creates a fitting ambience anywhere by using the full colour spectrum. LightWave's LED lamp can be built in, has variable dimensions and can be used as a single element or in combination with additional FLAT lamps.

- > Select directly from 26 colours and white light
- > Automated colour sequencing (through the entire spectrum)
- > Remote control
- > Energy saving
- > Even illumination of the area
- > Extra flat – 10 mm
- > Can be built in (see reverse for examples)
- > DMX/EIB controllable
- > Engravable (lettering)
- > Variable formats:  
50-600 mm x 200/400/600/800/1000/1200/1400 mm (LED-side)

## CONTACT

LightWave LED Products | Schlattweg 558 | 5704 Egliswil | Switzerland  
tel +41 62 775 44 35 | fax +41 62 775 33 14  
info@lightwave-led.com | www.lightwave-led.com

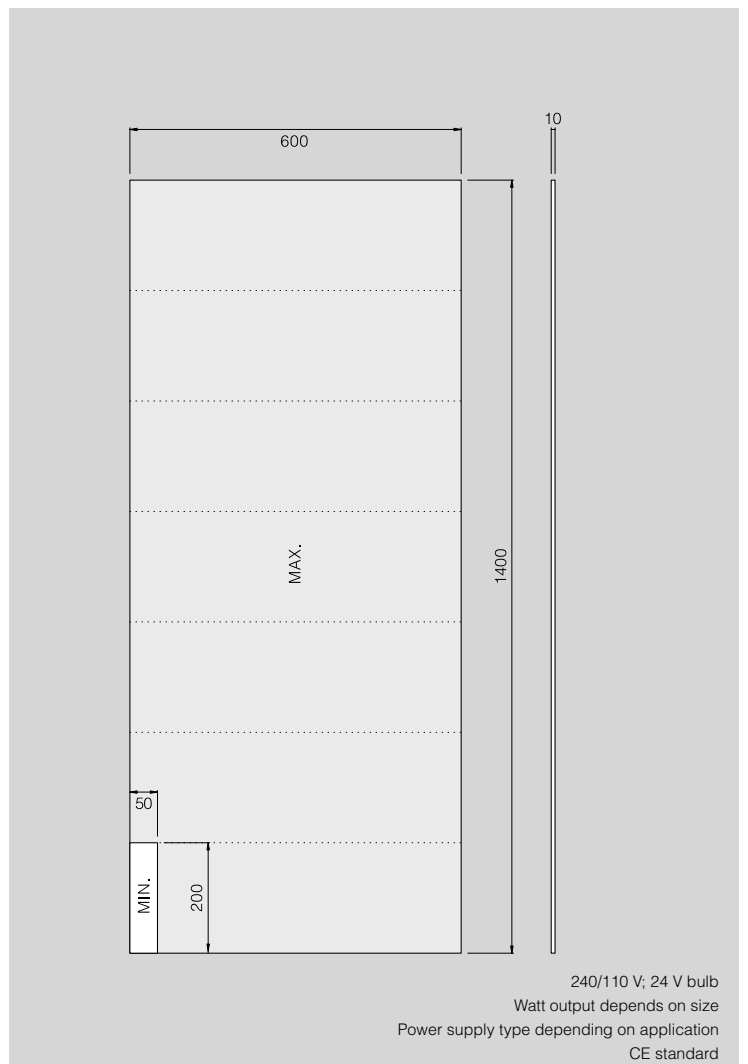

# APPLICATION EXAMPLES

> LightWave's engraved LED FLAT



> LightWave LED FLAT built into kitchen units



> Wall bracket for LightWave LED FLAT (DMX/EIB controllable)

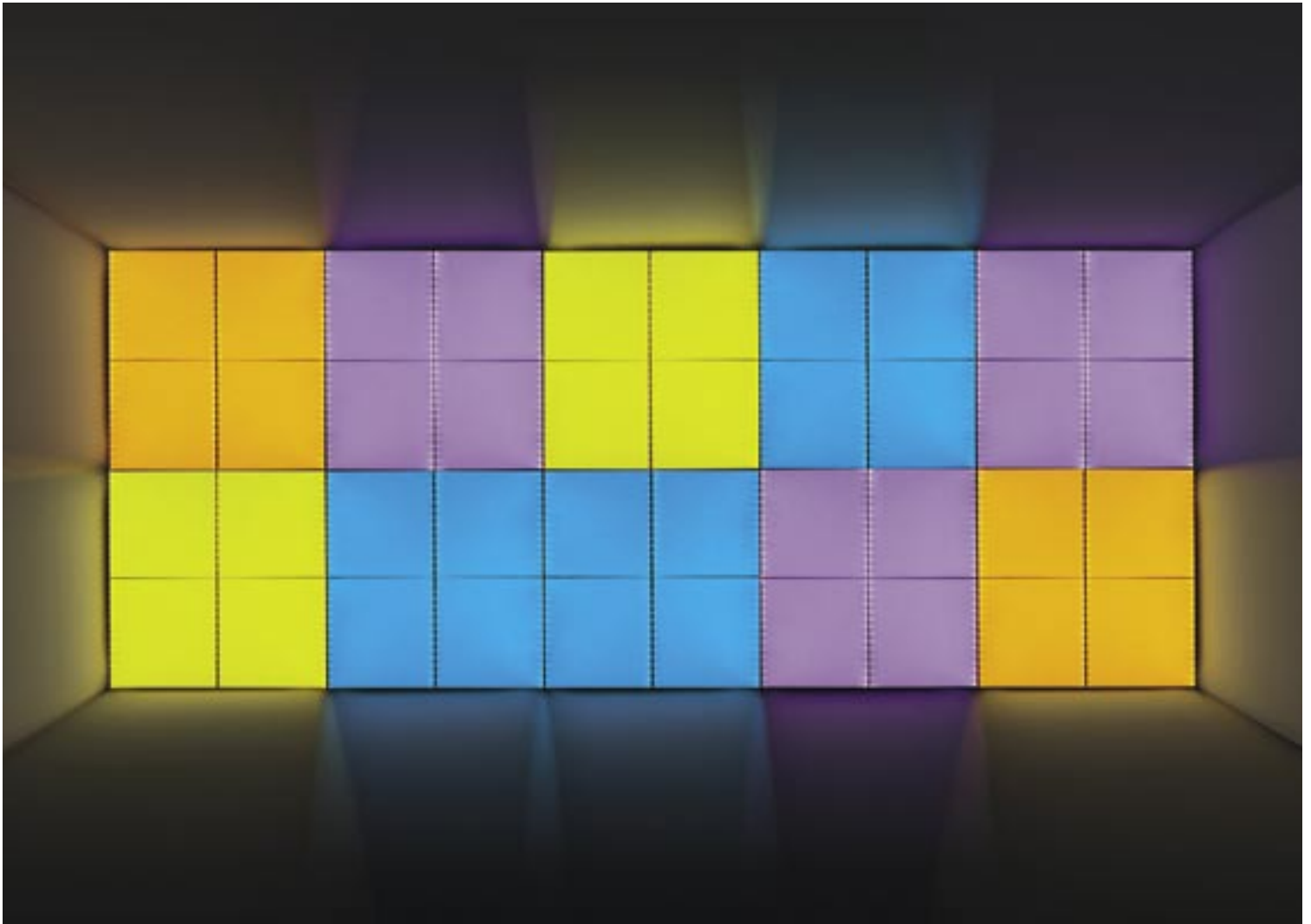

# I2.800I

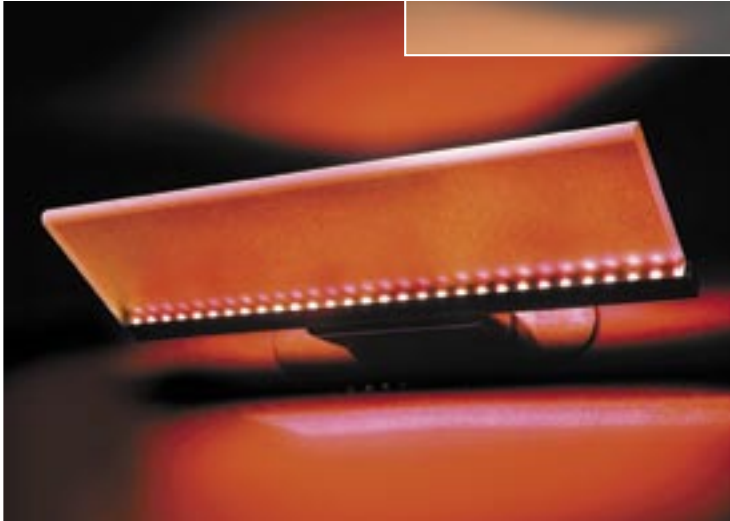

## I2.800I - WALL LAMP

LightWave's wall lamp can be angled up to 90°. Lighting effects on the ceiling and wall help create an expressive, intimate atmosphere.

- > Wall bracket can be angled up to 90°
- > Select between 26 different colours
- > Automated colour sequencing throughout the spectrum
- > Remote control
- > Energy-saving

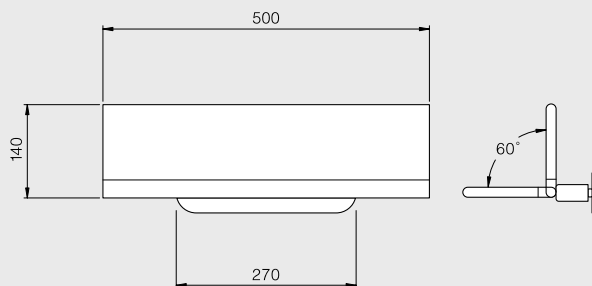

240/110 V; 24 V bulbs  
Output 7.2 W  
Power supply in wall bracket  
Quality standard: CE norm

# I2.900I



## I2.900I - TABLE LAMP

LightWave's table lamp creates the right emphasis for horizontal surfaces such as tables, sideboards and counters. It's popular in combination with other models of LightWave lamps, too. As with all LightWave's LED lamps, it can easily be engraved to your particular requirements.

- > Select between 26 different colours
- > Automated colour sequencing throughout the spectrum
- > Remote control
- > Energy-saving

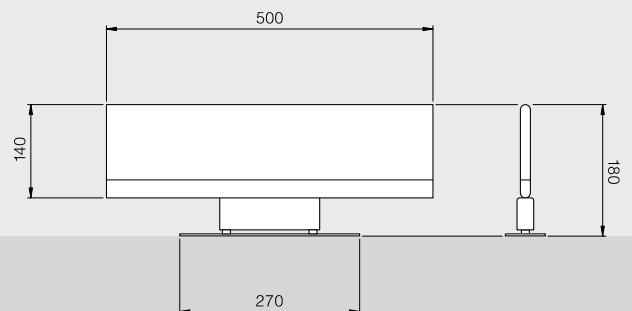

240/110 V; 24 V bulbs  
Output 7.2 W  
Plugs into any wall power supply  
Quality standard: CE norm



## CONTACT

LightWave LED Products | Schlattweg 558 | 5704 Egliswil | Switzerland  
tel +41 62 775 31 54 | fax +41 62 775 33 14  
info@lightwave-led.com | www.lightwave-led.com

made in Switzerland